

ECOPHON OPTA E

Ecophon Opta™ E has a recessed visible grid and a tegular edge design, creating a ceiling with a shadow effect to accentuate each tile and partially conceal the grid system. For applications requiring an easy-install suspended ceiling and meets basic functional demands.

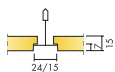

Ecophon Opta E



SYSTEM RANGE

Size, mm	600x600	1200x600
T15	•	•
T24	•	•
Thickness (THK)	15	15
Inst. Diagr.	M140	M140

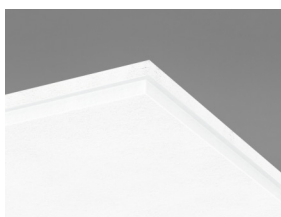

Opta E tile

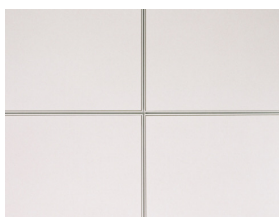

Section of Opta E system with Connect T24



Opta E system with Connect T24



ACOUSTIC

Sound Absorption

Test results according to EN ISO 354. Classification according to EN ISO 11654.

α_p , Practical sound absorption coefficient

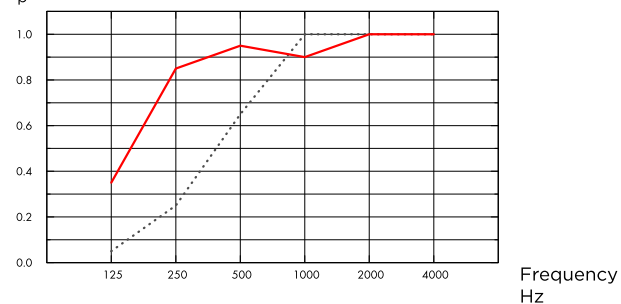

..... Opta E 15 mm, 60 mm o.d.s.

— Opta E 15 mm, 200 mm o.d.s.

o.d.s = overall depth of system

THK mm	o.d.s. mm	α_p , Practical sound absorption coefficient						α_w	Sound absorption class
		125 Hz	250 Hz	500 Hz	1000 Hz	2000 Hz	4000 Hz		
15	60	0.05	0.25	0.65	1.00	1.00	1.00	0.55	D
15	200	0.35	0.85	0.95	0.90	1.00	1.00	0.95	A

THK mm	o.d.s. mm	NRC	SAA
15	60	0.75	0.74
15	200	0.95	0.92



INDOOR AIR QUALITY

Certificate / Label	600x600, 1200x600
Eurofins Indoor Air Comfort®	IAC Gold
French VOC	A+



CARBON FOOTPRINT

Life-cycle stages A1 to C4 from EPD, in conformity with ISO 14025 / EN 15804

	kg CO ₂ equiv/m ²
Opta E	2,03 (Opta family EPD in conformity with ISO 14025 / EN 15804)



CIRCULARITY

Minimum post-consumer recycled content	51%
Recyclability	Fully recyclable



FIRE SAFETY

The glass wool core of the tiles is tested and classified as non-combustible according to EN ISO 1182.

Country		Class
Europe	EN 13501-1	A2-s1,d0



HUMIDITY RESISTANCE

Class C, relative humidity 95% and 30°C, according to EN 13964:2014



VISUAL APPEARANCE

White 190, nearest NCS colour sample S 1000-N, 80% light reflectance. Since the product has a coloured glasfelt as a surface, it can appear mottled, specially with indirect lighting. Slight colour differences can occur.



CLEANABILITY

Weekly dusting and vacuum cleaning.



ACCESSIBILITY

The tiles are easily demountable. Minimum demounting depth according to installation diagrams.



INSTALLATION

Installed according to installation diagrams, installation guides and drawing aid. (The tiles have to be installed according to the arrows on the back of the tile.)



SYSTEM WEIGHT

Weight information is indicative and subject to variation.

	kg/m ²
Opta E	1,2
Opta E + Connect grid system	2,2



MECHANICAL PROPERTIES

See table about Max live load and Min load bearing capacity and Functional demands, Mechanical properties at www.ecophon.com.



CE

Ecophon ceiling systems are CE marked according to the European harmonized standard EN13964:2014. CE marked construction products are covered by a Declaration of Performance (DOP) which enables customers and users to easily compare performance of products available on the European market.

Suspended ceiling

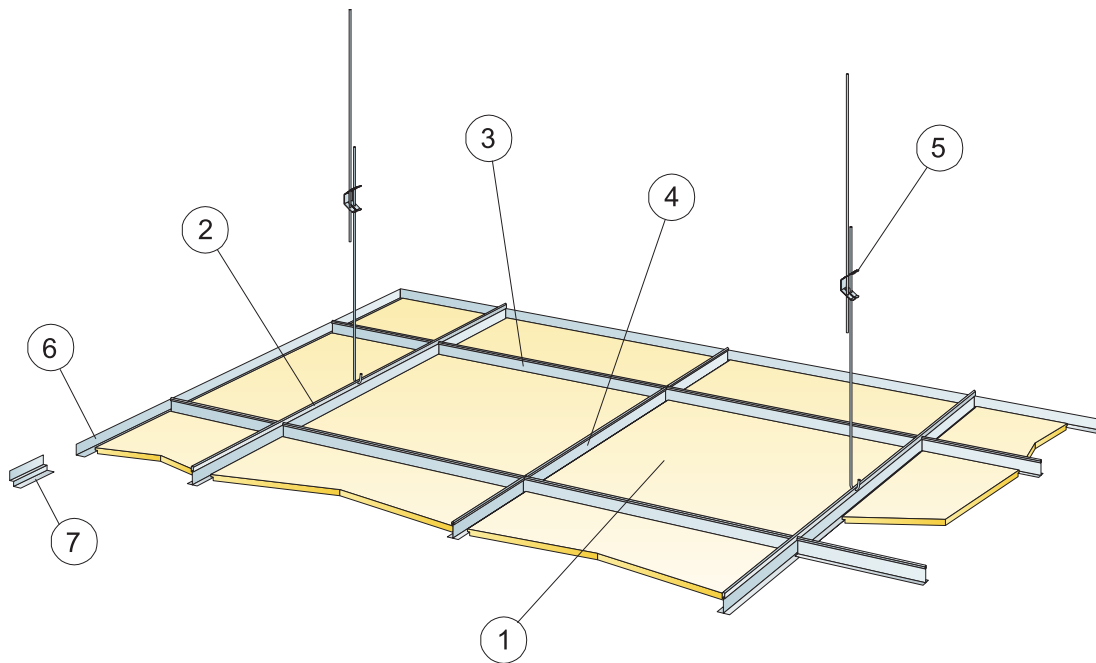

© Ecophon Group

Installation diagram (M140) for Ecophon Opta E

Quantity specification (excl. wastage)

	Size, mm	
	600x600	1200x600
1 Opta E	2,8/m ²	1,4/m ²
2 Connect T24 or T15 Main runner, installed at 1200 mm centres (max. distance from wall 600 mm, can be extended up to 1200 mm if no live load between Main runner and wall).	0,9m/m ²	0,9m/m ²
3 Connect T24 or T15 Cross tee, L=1200 mm, installed at 600 mm centres	1,7m/m ²	1,7m/m ²
4 Connect T24 or T15 Cross tee, L=600 mm	0,9m/m ²	-
5 Connect Adjustable Hanger, installed at 1200 mm centres (max. distance from wall 600 mm)	0,7/m ²	0,7/m ²
6 Connect Angle Trim, fixed at 300 mm centres	as required	as required
7 Connect Shadow-line trim, fixed at 300 mm centres	as required	as required
Δ Min. overall depth of system: 110 mm	-	-
δ Min. demounting depth: 120 mm	-	-

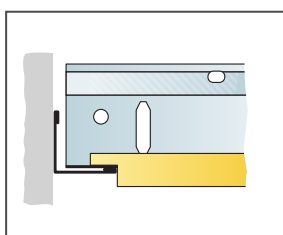
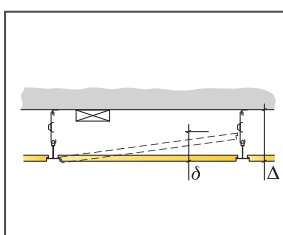

Regular rebate with angle trim.

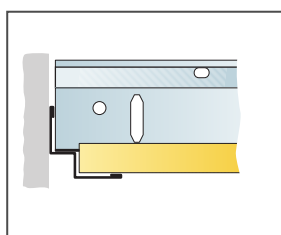

Straight cut with T-profiles resting on upper part of Shadow-line trim.

Size, mm	Max live load (N)	Min load bearing capacity (N)
600x600x15	50	160
1200x600x15	50	160

Live load/load bearing capacity